

DATA SHEET



PD-Monitor® Description:

A wall mounted and factory tested differential pressure monitoring unit incorporating controller, 2 off pressure transducers, 115V AC mains cable and enhanced BMS capabilities.

Product Code:

NAMONXPOTPD

Technical Specification -

Parameters:	Differential Pressure
IP Protection:	IP54
Mounting Position:	Internal Wall - Frost Free
Display:	Dot Matrix (Red)
Electrical Connections:	3FT 115V Power Cord (Supplied with B Type Plug) Connected to isolator (by others)
Power Supply:	115v AC, 60 Hz, 13.5 mA
Dimensions:	7.9" x 5.9" x 3.3"
Weight:	2.9 lbs
Ambient Operating Temperatures:	>41°F to 113°C, <90% RH
Pressure Sensor Cable:	Packard Plug + Cable (70" length)
Pressure Sensor Material:	ANSI 316L
Max Working Pressure (Sensors):	<435 PSI
Differential Pressure Increments:	1 PSI
Range of Pressure Differential:	1 to 101 PSI
4-20mA Sensor Connections:	¼" NPT
Max Working Temperature (Sensor):	212°F
Min Working Temperature (Sensor):	-40°F
Medium:	Water / Liquids
BMS Signal:	5 amp Dry Contact Relay Common Alarm and/or Modbus RS485 (Address List on Page 4) used to contact BMS System (Normally Open). BACnet or other communication gateway as required by others
Max Glycol System Mix:	40%

Applications -

The VEXO® PD-Monitor is a flexible solution and ideally suited for commercial and industrial heating/cooling systems.

Blockages in plant equipment such as filters, strainers, plate heat exchangers and heater coils can have a detrimental effect on the system efficiency and building comfort.

VEXO® PD-Monitor can be used to detect blockages and will alarm locally with audible buzzer and visual beacon and remotely via a BMS fault signal (relay / Modbus) when connected to a BMS system.

PD-MONITOR ILLUSTRATION

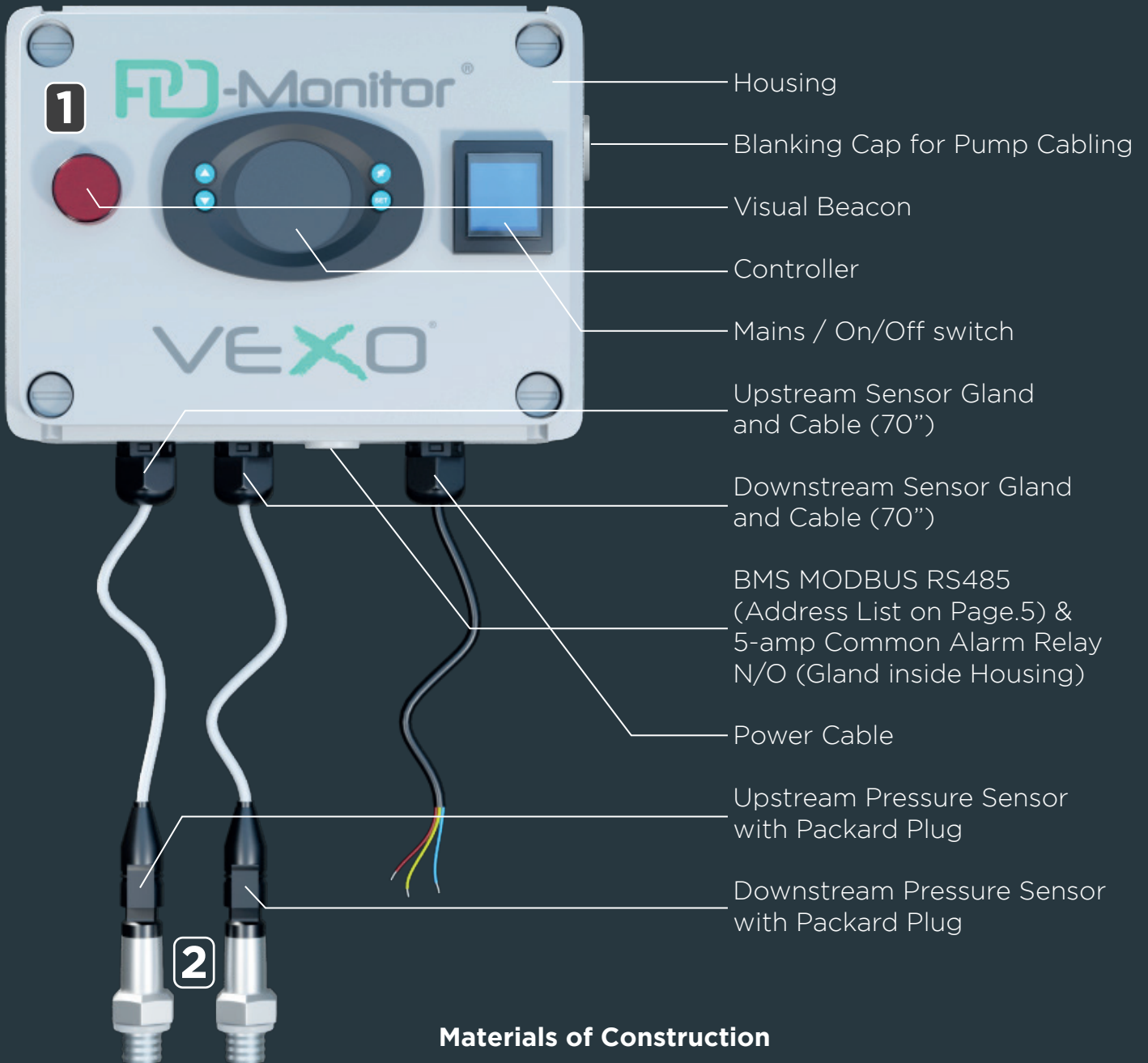

- Housing
- Blanking Cap for Pump Cabling
- Visual Beacon
- Controller
- Mains / On/Off switch
- Upstream Sensor Gland and Cable (70")
- Downstream Sensor Gland and Cable (70")
- BMS MODBUS RS485 (Address List on Page.5) & 5-amp Common Alarm Relay N/O (Gland inside Housing)
- Power Cable
- Upstream Pressure Sensor with Packard Plug
- Downstream Pressure Sensor with Packard Plug

Materials of Construction

- 1. Housing: Techno Polymer GWPLAST 75
- 2. Pressure Sensor: ANSI 316L

Dimensions -

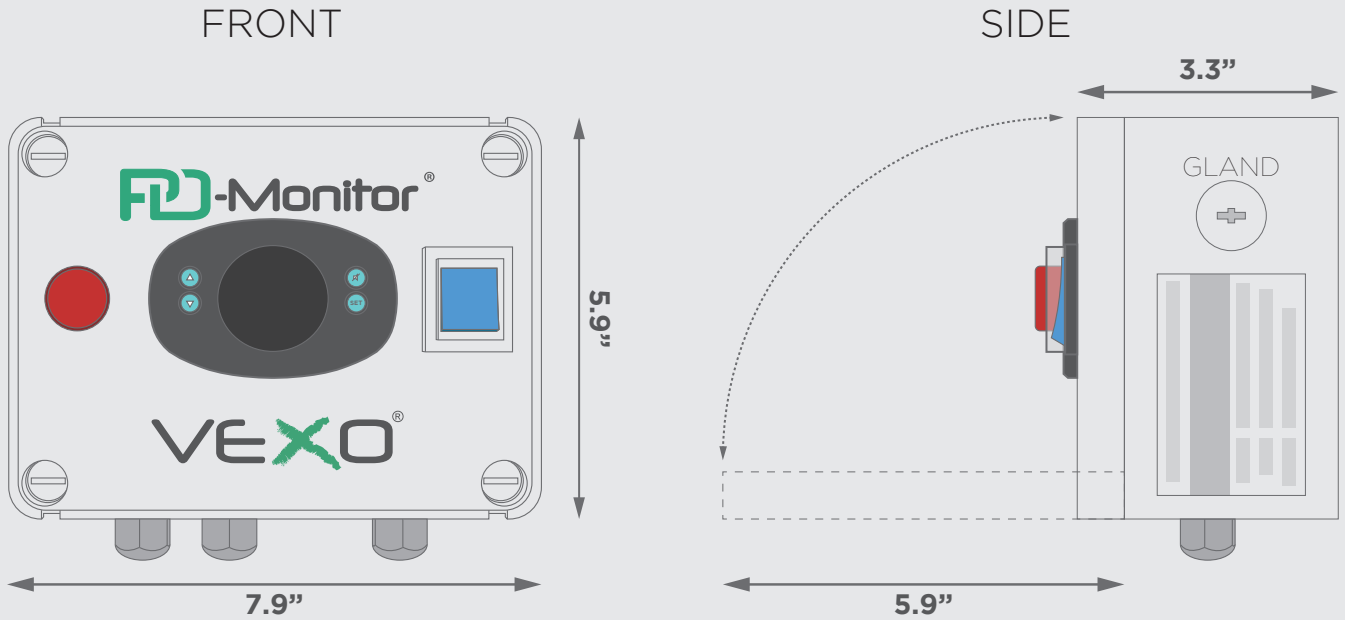

Leave at least 4" free space in all directions to ensure sufficient access and 8" from the front of the unit to enable unhindered opening of the front service panel.

BACK (Mounting Holes)

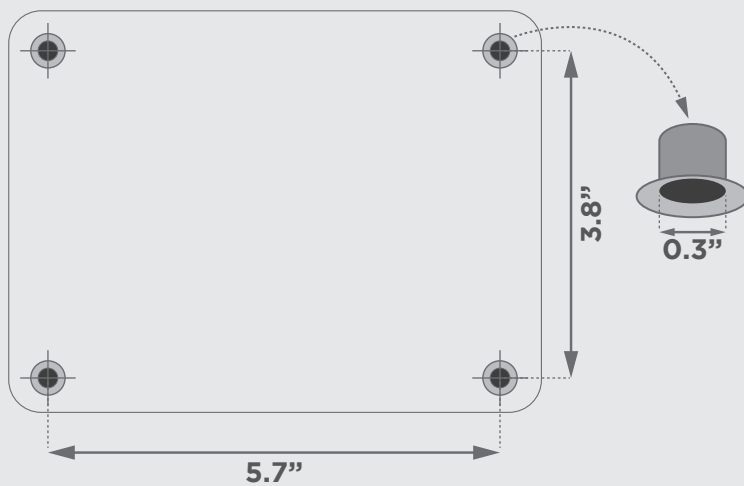

PRESSURE SENSOR

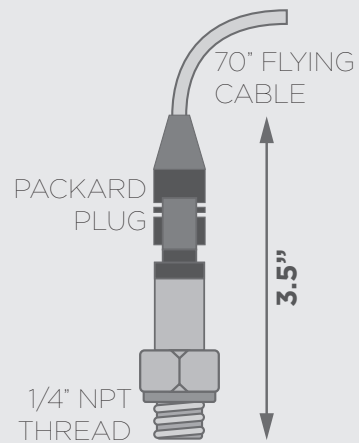

MODBUS Address List -

Preliminary Settings				
Baud Rate		9600		
Word Length		8		
Parity		NO		
Stop Bits		1		
X Variable Address	Denomination	Type	X Variable Format	Description
40001	Pressure Sensor 1	Read	Word	Value of Sensor 1
40002	Pressure Sensor 2	Read	Word	Value of Sensor 2
40003	Current	Read	Word	Value of current through pump
40006	Pump Relay	Read	Word	Status of Pump Relay
40007	Filter Pump Alarm Relay	Read	Word	Status of Pump Relay
40008	General Alarm Relay	Read	Word	Status of General Alarm Relay
40009	Buzzer	Read	Word	Status of Buzzer
40013	Filter Blocked Alarm	Read	Word	Status of Filter Blocked Alarm
40014	Pump Failure Alarm	Read	Word	Status of Pump Failure Alarm
40015	Sensor 1 Alarm	Read	Word	Status of Sensor 1 Alarm
40016	Sensor 2 Alarm	Read	Word	Status of Sensor 2 Alarm
40023	Par. Pressure Diff.	Read/Write	Word	Value of the Parameter
40024	Par. Alarm Relay Contact	Read/Write	Word	Value of the Parameter
40025	Par. Minimum Pressure	Read/Write	Word	Value of the Parameter
40026	Par. Maximum Pressure	Read/Write	Word	Value of the Parameter
40027	Par. Current Sense	Read/Write	Word	Value of the Parameter
40028	Par. Bar/PSI Unit	Read/Write	Word	Value of the Parameter
40029	Par. Buzzer Enable	Read/Write	Word	Value of the Parameter
40030	Par. Pressure Diff. Message	Read/Write	Word	Value of the Parameter
40031	Par. ID Number	Read/Write	Word	Value of the Parameter
40032	Par. Pump Hours	Read/Write	Word	Value of the Parameter
40033	Par. Alarm Counter	Read/Write	Word	Value of the Parameter

Continued on following page...

MODBUS List (Continued) -

X Variable Address	Data Conversion	Units	Range of X Variable
40001	Pressure Sensor 1	Decimal of Bar/PSI	
40002	Pressure Sensor 2	Decimal of Bar/PSI	
40003	Current	mA	
		Preliminary Settings	
40006	Pump Relay	Baud Rate	9600
40007	Filter Pump Alarm Relay	Word Length	8
40008	General Alarm Relay	Parity	NO
40009	Buzzer	Stop Bits	1
40013	Filter Blocked Alarm	Read	
40014	Pump Failure Alarm	Read	
40015	Sensor 1 Alarm	Read	
40016	Sensor 2 Alarm	Read	
40023		Read/Write	1 -> 70
40024	Par. Alarm Relay Contact		0 -> 1
40025		Read/Write	0 -> Par. Maximum Pressure
40026		Read/Write	Par. Minimum Pressure -> 30
40027	Par. Current Sense		4 -> 5
40028	Par. Bar/PSI Unit		2 -> 3
40029	Par. Buzzer Enable		4 -> 5
40030	Par. Pressure Diff. Message		1 -> 5
40031			0 -> 99
40032		Hours	1 -> 9999
40033			0 -> 1000

VEXO[®]

www.VEXOint.com

technical@VEXOint.com

+1 (800) 917-6735

PROTECTING NATURE

- IS OUR -

SECOND NATURE

X-POT & PD-Monitor are registered trade marks of VEXO International (UK) Ltd.