

100 GALLON OUTDOOR GLYCOL FEED SYSTEMS OPERATIONS & MAINTENANCE



Unit Description

Glycol Feed Units are complete packaged assemblies which are plumbed, wired and tested at the factor. Units are designed to provide an automated and maintained supply of a water-glycol mix, under pressure, to a closed loop heating or cooling system (see Fig. 5 for part specifications).

Installation Instructions

1) Location

Locate unit in an area that provides ample room for maintenance personnel to service and maintain the unit. Suitable electrical service should also be available at site.

2) Mounting

Mount unit to a level floor using anchor bolts that are sized to the units mounting feet (see dimensional drawing Fig. 4 for simplex / Fig. 5 for duplex).

3) Plumbing

Unit comes with a standard 1/2" N.P.T. discharge. Plumb discharge into the make-up line on the closed loop system (Fig.4).

NOTE: Only use pressure rated and approved pipe. Do not over tighten fittings. Support discharge line with proper pipe hangers.

4) Electrical

Unit is supplied with a 9 ft. 110v. 1ph. power cord. Unit is to be plugged into a 110v. AC ground fault interrupt receptacle with appropriate circuit breaker protection (see label inside of panel for specific electrical ratings).

NOTE: Simplex unit requires a 15amp rated receptacle. (Fig.5)

Duplex unit requires hard wiring to a 20 amp rated circuit (no power cord supplied). (Fig. 6)

Unit Adjustable Components

- 1) Pressure Switch: Adjustments are made to change the pressure at which the pump turns on and off (Fig. 1).

Note: See next page for details.

Unit Startup

- 1) Fill tank with glycol mix.
- 2) Ensure all switches on the enclosure are in the off position and plug in the power cord.
- 3) Open the suction line gate valve to the pump and open the discharge line to the system.
- 4) Turn power switch to the on position. Ensure the power light is on.
- 5) Turn the pump switch to the hand position to prime the pump. When pump is primed, turn the pump switch to the on position. The pump will run until the cut-out limit on the pressure switch is satisfied.

System Operation

The Glycol Feed Pump will turn on and activate when the system pressure falls below the cut-in setting on the pressure switch. The cut-in setting is factory set at 10 PSI, but is field adjustable (Fig. 1). The pump will continue to run until the pressure switch reaches the cut-out limit. The cut-out limit is factory set at 40 PSI, but is also field adjustable (Fig. 1).

Maintenance

- A) The glycol tank must be monitored and filled on a regular basis. Glycol mix is to be added by lifting the hinged cover and pouring the mix into the tank. If the tank is pumped all the way down, the low water float switch will activate the alarm and will shut down the unit to avoid the pump or pumps running dry.
- B) Periodic maintenance will also be required on the pump suction strainer. Unit is to be shut down, close the suction gate valve and remove the strainer cap built into the pump. The screen can now be removed and cleaned (Fig. 4).

Warning

Failure to keep screen clean will result in a pump run dry condition resulting in pump failure.

Pressure Switch Setting

#1 - Large spring adjustment nut changes both cut-on (pump on) and cut-off (pump off) pressure adjustment.

#2 - Small spring adjustment nut changes just cut-off pressure adjustment.

Device Adjustment

1 complete turns = 2 PSI approximate
5 complete turns = 10 PSI approximate

Turn adjustment nuts clockwise (cw) to increase pressure.

Turn adjustment nuts counter clockwise (ccw) to decrease pressure.

Factory Settings = On at 10 PSI / Off at 40 PSI

Adjustment Example

Change switch from factory settings to On at 30 PSI / Off at 50 PSI

- A) Set the cut-on pressure (pump on). Turn #1 nut cw 10 turns.
- B) Set the cut-off pressure (pump off). Turn #2 nut ccw 5 turns.

#2 Small Spring

Changes cut-off pressure only

#1 Small Spring

Changes both cut-on and cut-off pressure

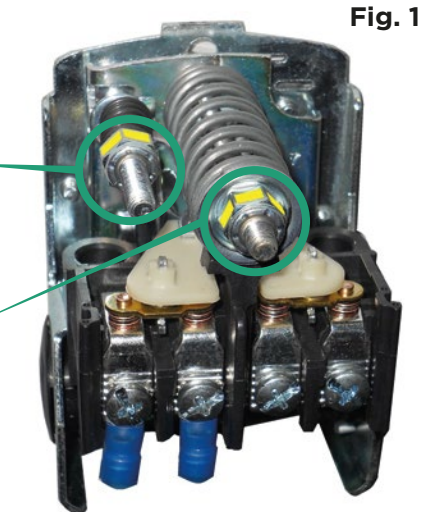


Fig. 1

This sets the switch to on at 30 PSI / off at 60 PSI.
This sets the switch to on at 30 PSI / off at 50 PSI.

Auxiliary Alarm Contacts

Every unit is equipped with an auxiliary alarm dry contact. The dry contact is located inside the control panel and is pre-wired to the terminal strip, poles 9 and 10. This dry contact can be used for a remote alarm location or for a building management system.

NOTE: See label inside of panel for wire size and torque.

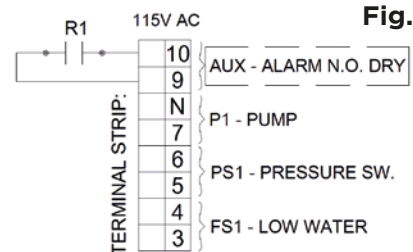


Fig. 3

Pump Suction Strainer

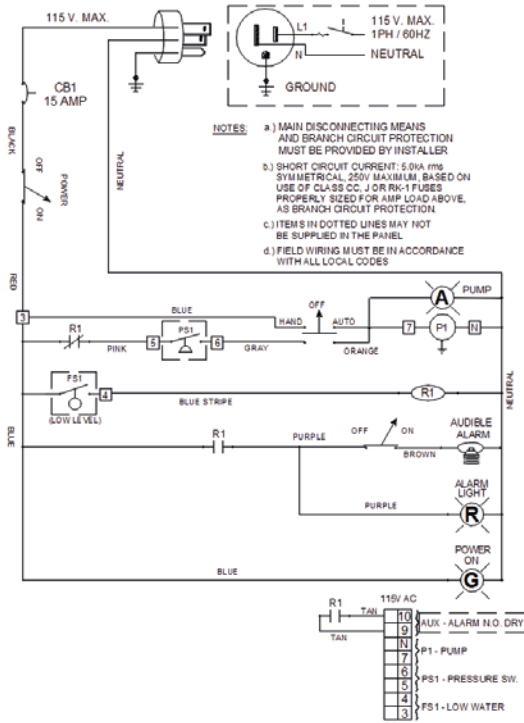
Periodic maintenance will also be required on the pump suction strainer. Unit must be shut down and valves closed before the cap and screen can be removed.

Turn the cap counter clockwise to unscrew cap. Pull screen down and out, clean and reassemble.

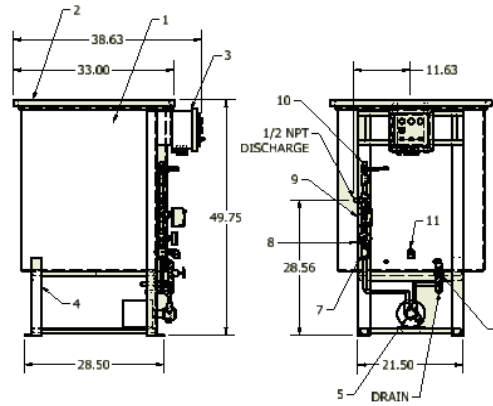
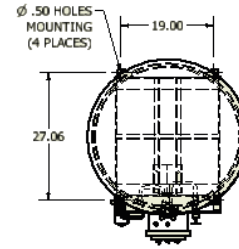


Fig. 4

Fig. 5



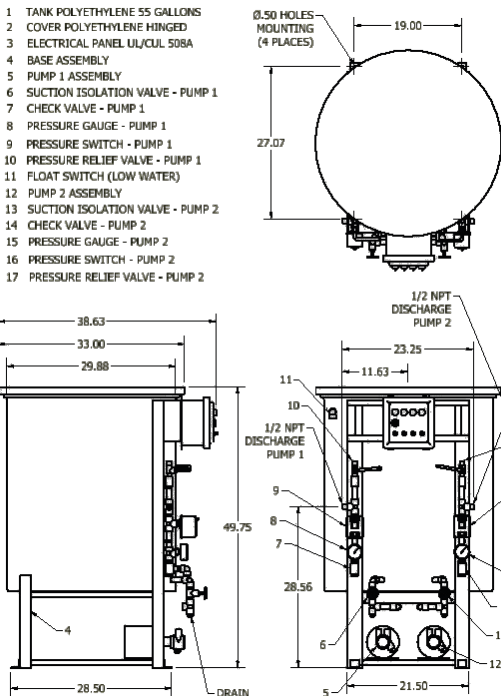
- 1 TANK POLYETHYLENE 100 GALLONS
- 2 COVER POLYETHYLENE
- 3 ELECTRICAL PANEL UL/CUL 508A
- 4 BASE ASSEMBLY
- 5 PUMP 1 ASSEMBLY
- 6 SUCTION ISOLATION VALVE - PUMP 1
- 7 CHECK VALVE - PUMP 1
- 8 PRESSURE GAUGE - PUMP 1
- 9 PRESSURE SWITCH - PUMP 1
- 10 PRESSURE RELIEF VALVE - PUMP 1
- 11 FLOAT SWITCH (LOW WATER)



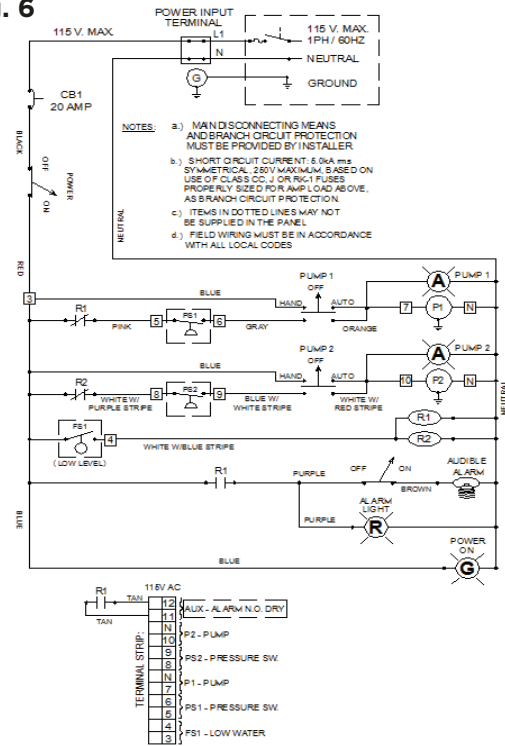
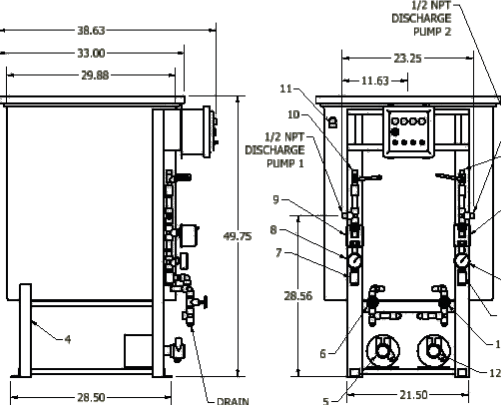
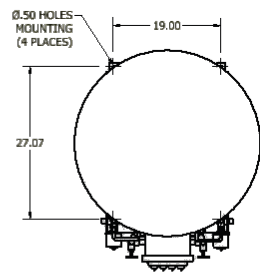
Note: All dimensions are approximate

Simplex S-100-100-2-PEFS

Fig. 6



- 1 TANK POLYETHYLENE 55 GALLONS
- 2 COVER POLYETHYLENE HINGED
- 3 ELECTRICAL PANEL UL/CUL 508A
- 4 BASE ASSEMBLY
- 5 PUMP 1 ASSEMBLY
- 6 SUCTION ISOLATION VALVE - PUMP 1
- 7 CHECK VALVE - PUMP 1
- 8 PRESSURE GAUGE - PUMP 1
- 9 PRESSURE SWITCH - PUMP 1
- 10 PRESSURE RELIEF VALVE - PUMP 1
- 11 FLOAT SWITCH (LOW WATER)
- 12 PUMP 2 ASSEMBLY
- 13 SUCTION ISOLATION VALVE - PUMP 2
- 14 CHECK VALVE - PUMP 2
- 15 PRESSURE GAUGE - PUMP 2
- 16 PRESSURE SWITCH - PUMP 2
- 17 PRESSURE RELIEF VALVE - PUMP 2



Duplex D-100-100-2-PEFS