

5 & 16 GALLON GLYCOL FEED UNIT SS-S-5-16

Furnish and install according to plans and manufacturers' instructions, a complete prefabricated, automatic glycol feed makeup unit. Each unit shall consist of a polyethylene tank with twist-open lid, low water float switch, self-priming diaphragm pump, 1/4" NPT brass swivel discharge, recirculation valve, 12v UL-listed power supply, 5A automotive-style fuse, pressure regulating valve, and pressure gauge.

Tank

Tank shall be heavy duty polyethylene with graduated scale. Lid shall be twist-on and large enough to access tank interior by hand.

5 Gallon 16 Gallon

Pump

Pump shall be self-priming diaphragm type with built-in suction strainer: 12vdc. 1ph. with built in dry-run protection. Pump will be capable up to 1.1 GPM @ 40PSI.

Wiring

Electrical wiring to be complete in the unit panel. Power is to be supplied to an external power jack via a UL listed 12v power supply. Circuit to be protected by means of a 5-amp automotive-style inline fuse.

Discharge Piping

Discharge shall be a 1/4" NPT brass Swivel connector at the end of a length of flexible high-pressure poly reinforced braided hose.

Low Level Switch

Float switch shall be made of ABS plastic. The float will be fixed to the top of the tank. Low tank level will deactivate all pumping operations until glycol mixture level has been restored.

Standard System Settings

G.P.M. 1.1 SYSTEM PRESSURE: ON - 11 PSI / OFF - 14 PSI PRESSURE RELIEF VALVE: 14 PSI

Power Requirements

VOLTAGE: 110v / 1ph / 60Hz F.L.A. 3.0 AMPS

Low Voltage Operation

Unit includes a UL listed 115vac to 12vdc power supply and power indication light.

Options

Digital Controller (replaces pressure regulating valve and pressure gauge)
- Includes digital controller with built in dot-matrix display, pressure transducer, low water alarm, high/low pressure alarm, dry contacts for alarm signal.

Wall Mounting Bracket (5 Gallon Units Only)

Note

GLYCOL FEED PART NUMBERS = "S" + ____ (TANK SIZE: "5","16")
+ "PEFS" + ____ (CONTROL TYPE: "V" - DIGITAL CONTROLLER, "P" - PRESSURE REGULATING VALVE)
EXAMPLE: S-16-PEFS-V (5 GALLON DIGITALLY CONTROLLED GLYCOL FEED)

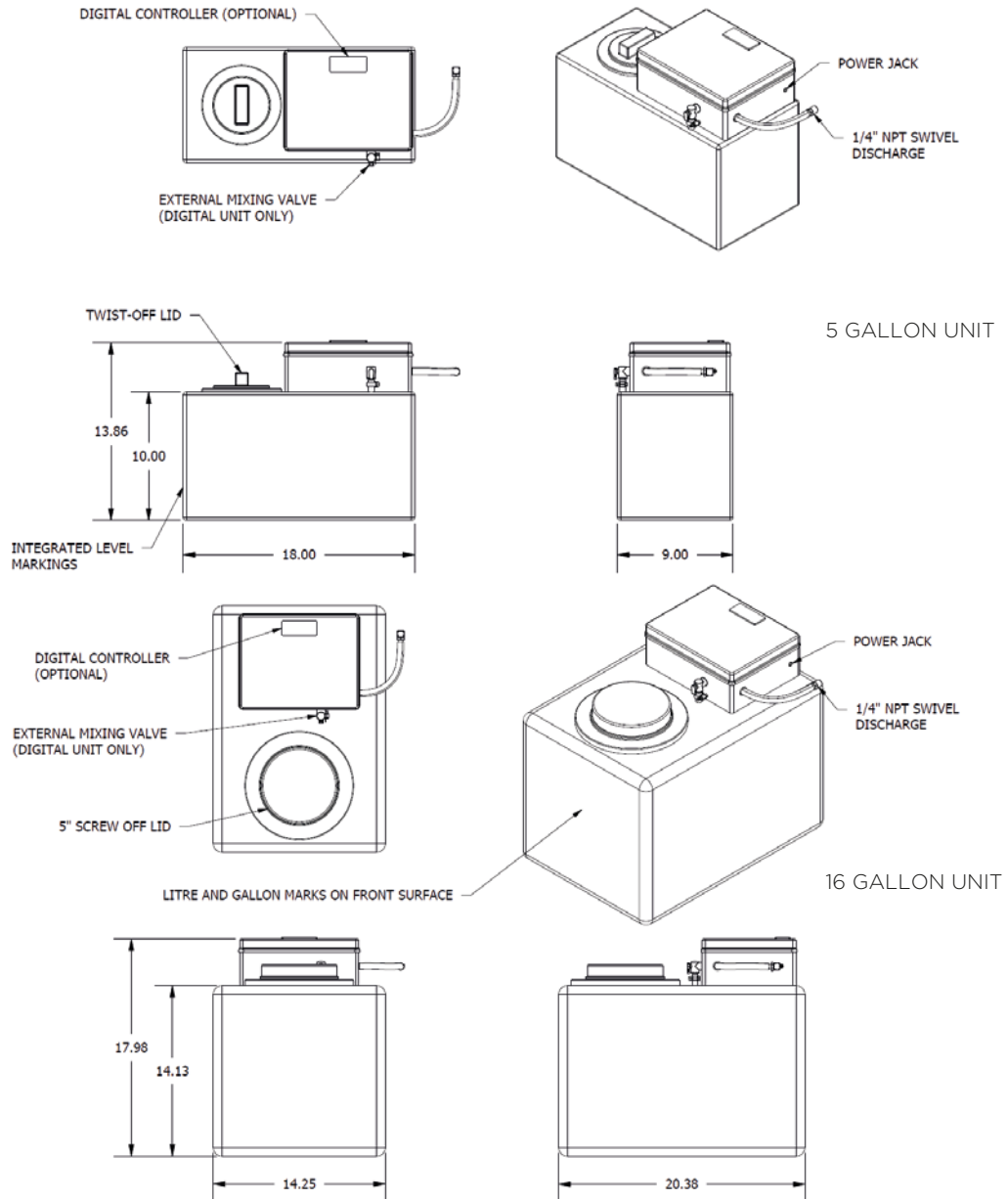

JOB NAME		CONTRACTOR	
ORDER NO.		SUBMITTED BY	DATE
SALES REP.		APPROVED BY	DATE
ENGINEER		NOTES	
LOCATION			