

5 - 16 GALLON GLYCOL FEED UNITS OPERATIONS & MAINTENANCE

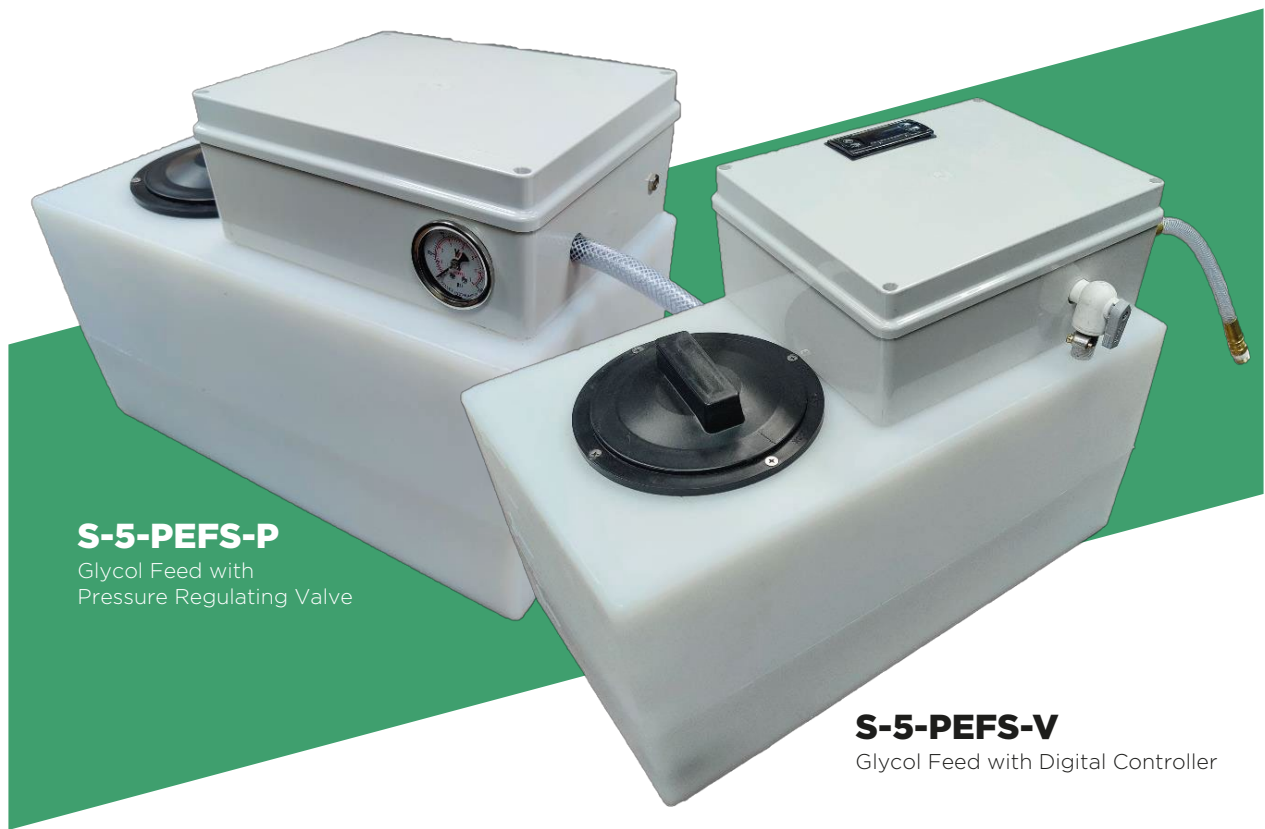

S-5-PEFS-P
Glycol Feed with
Pressure Regulating Valve

S-5-PEFS-V
Glycol Feed with Digital Controller

Introduction

This form contains information necessary to install, operate and maintain Glycol Feed Units manufactured by Skidmore®. The information is assembled in order, from receiving the product to its proper maintenance, to enable you to follow the product through the various steps necessary to implement.

The VEXO® Glycol Feed Unit is designed to bring an automatic supply of water-glycol mix to any heating or cooling closed-loop system. Factory engineered and assembled, Glycol Feed units are available in 5- and 16-gallon capacities, with custom sizes available upon request. These compact and self-contained units make for an easy install and no-hassle operation. Easy plug 'n play run capability also allows for immediate usage.

Installation & Operation

It is not necessary to install a pressure regulation valve or check valve between the glycol feeder and the system. Rather, there must be an isolation valve separating the feeder from the system. The system must be installed on a flat, level surface to ensure proper operation.

First Time Set Up:

1. Open the lid and inspect the interior of the tank.
 - a. Ensure that the suction hose filter is clear of obstructions and rests at the bottom of the tank.
 - b. Check operation of the float, ensuring that the float is vertical and slides up and down freely.
2. Reattach lid, and plug in the power adapter, pump should not start. Disconnect the power adapter.
For digital systems: System will boot up, wait about 10 seconds, then a low water alarm will sound. Disconnect the power adapter.
3. Test glycol feed operation.
 - a. Connect 1/4" swivel connector to system via isolation valve, ensuring isolation valve is fully closed
 - b. For Non-Digital systems only: Unscrew the four fastening screws on the lid of the pump enclosure and remove.
 - c. Open the mixing valve.
 - d. Fill the unit with glycol/water solution.
 - e. Plug in the power adapter. Unit will begin to cycle glycol mixture. Once glycol has been satisfactorily mixed, close the mixing valve.
4. Open the isolation valve and allow the system to pressurize.
5. **(Optional)** Adjusting the system pressure. (By default, all glycol units will fill to 14 PSI/10 Bar)
 - a. **For Non-Digital systems:**
 - i. Close the isolation valve.
 - ii. Unscrew the four fastening screws on the lid of the pump enclosure and remove.
 - iii. Adjust the central screw of the pressure regulating valve until the gauge reads the desired value. Relieving pressure as necessary with the mixing valve.
 - b. **For Digital systems:**
 - i. Follow instructions printed on pump enclosure lid.

Wall Mounting (Optional, 5 Gallon Only):

1. Locate the bracket (sold separately) on the wall. Bracket holes are located 16" apart, 2" below the top of the unit. Use #8 or #10 screws with a wide flat head to hang the unit, with sufficient depth to secure the unit firmly to the wall.

Maintenance

The VEXO® Glycol Feed system does not require any regular maintenance.

Typical System Connections

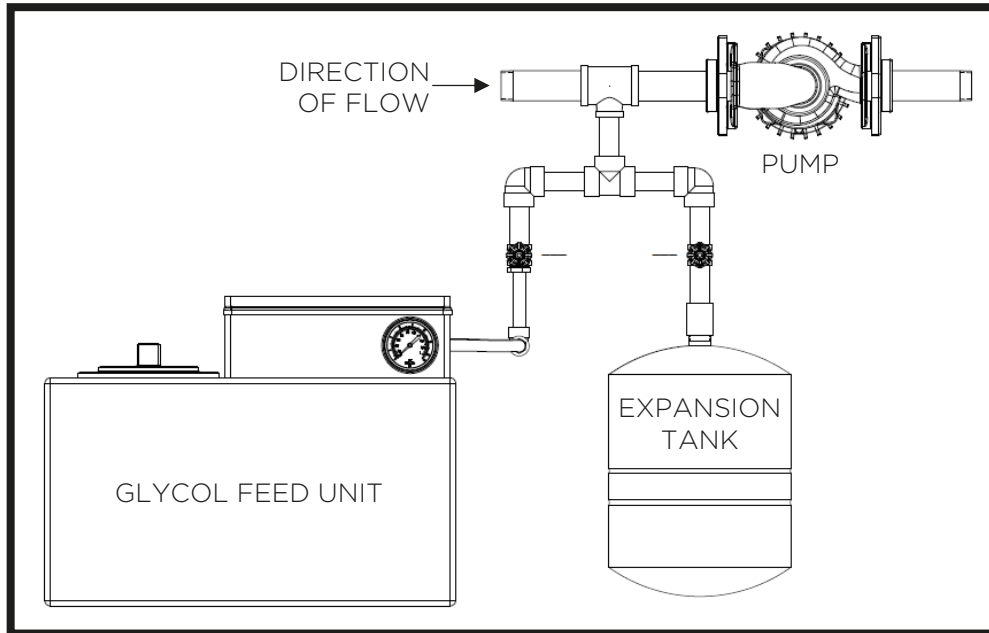

Troubleshooting

A troubleshooting chart is shown below to enable you to isolate any problems you may encounter when operating the VEXO® Glycol Feed Unit.

Symptom	Possible Cause	Remedy
1. Substantial pressure difference between feeder discharge and system.	1a. Isolation valve is closed. 1b. Check valve is installed between system and feeder. 1c. Large height difference between system pressure gauge and system feeder. 1d. Faulty pressure gauge.	1a. Open isolation valve. 1b. Remove check valve and replace with isolation valve if none is present. 1c. Elevate the glycol system feeder using the optional mounting bracket, 5 gallon only. 1d. Replace pressure gauge.
2. Pump does not start at low system pressure.	2a. See 1b. 2b. Glycol mixture level is too low. 2c. Blown fuse or faulty power supply. 2d. Float switch stuck. 2e. Faulty pump.	2a. See 1b. 2b. Inspect system for leaks and replace glycol mixture, see 3c-3d of the start-up guide (Pg.2). 2c. Check system fuse (5A), check power supply and replace if needed. (12V, 5A) 2d. Check that the float switch slides easily up and down, if the pump starts when the float is down, the float is incorrectly set and must be flipped around. 2e. Replace pump.
3. Pump cycles continuously.	3a. Air is being purged from system, and pump is replacing empty space 3b. with mixture. See 1b. 3c. Leak in system.	3a. No additional action require pump should stop after short time. 3b. See 1b. 3c. Inspect system for leaks.

Repair Parts List

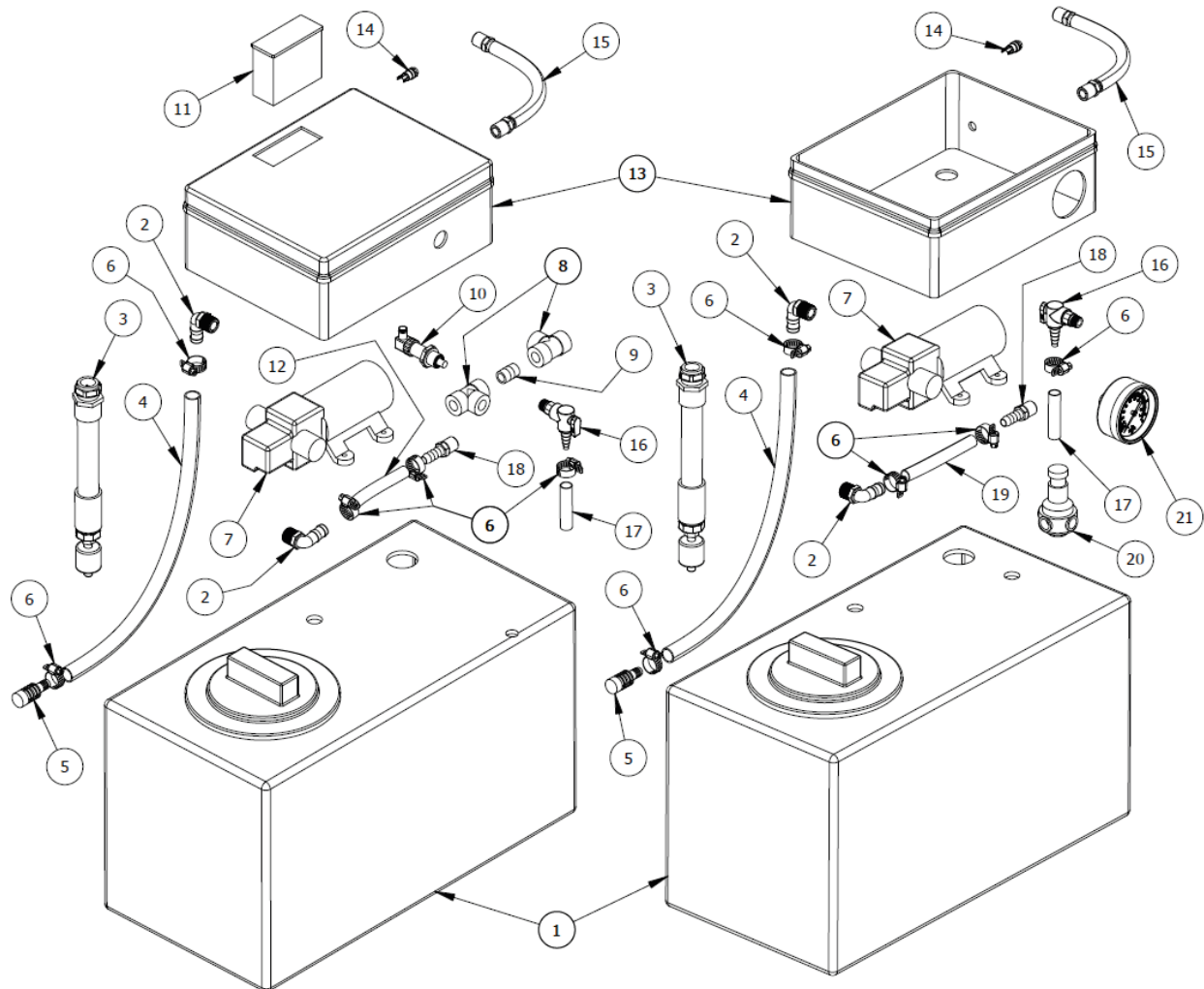

Glycol Feed with Digital Controller

Glycol Feed with Pressure Regulating Valve

Repair Parts List (Continued)

Item Number	Description	Skidmore® P/N	Quantity
1	5 Gallon Tank	58691-5	1
1	16 Gallon Tank	58691-16	1
2	Motor Barbed Fitting	58808-1	2
3	5 Gallon Float Assembly	58491-5-ASSY	1
3	16 Gallon Float Assembly	58491-16-ASSY	1
4	Suction Hose	58735	1
5	Inlet Strainer	58744-1	1
6	Hose Clamp	58736-1	5
7	Pump	58701-11	1
8*	SCH 80 1/4" NPT Tee	58813-1	2
9*	SCH 80 1/4" Close Nipple	58812-1	1
10*	Pressure Transducer	58816	1
11*	Digital Controller	58815	1
12*	3/8" Braided Hose	58735	1
13	Pump Enclosure	58811-1	1
14	Power Socket	58734	1
15	1/4" NPT Swivel Discharge Hose	58703	1
16	1/4" NPT Ball Valve	58732-1	1
17	1/4" Hose	235348	1
18	1/4" X 3/8" Barbed Fitting	58809-1	1
19***	3/8" Braided Hose	58735	1
20***	Pressure Reducing Valve	58810-1	1
21***	Pressure Gauge	51054-2	1