

DUPLEX 55 GALLON GLYCOL FEED UNIT D-55-100-2-PEFS

Furnish and install according to plans and manufacturers' instructions, a complete prefabricated, automatic glycol feed makeup unit. Each unit shall consist of a steel frame base, polyethylene tank with hinged removable cover, low water cut-off alarm, two brass rotary vane pumps with built in suction strainers, Nema 4X control panel, brass suction and discharge piping, pump isolation valves, discharge check valves, pressure switches, pressure gauges, pressure relief valves, and interconnecting piping. The duplex unit is set up for use with two separate heating or cooling loop systems unless the ALT (alternator) option is used.

Tank and Base Assembly

Tank shall be 55-gallon industrial grade polyethylene with graduated scale. Cover shall be hinged with a stainless-steel piano hinge. The base assembly shall be made of structural steel welded together and painted with a powder coat process for high durability.

Pumps

Pumps shall be rotary vane close coupled type with brass housing and built in suction strainers. Pump motors are open drip proof type, 1/3 hp, 110v, 1ph with built in auto reset thermal overload. Pumps will be capable of 2 GPM @100 PSI.

Control Panel

Electrical control panel assembly shall be Nema 4X UL/CUL 508A listed, labeled and rated at 110v, 1ph, 60Hz. Panel shall have an audible alarm for low water, H.O.A. selector switches and yellow pilot lights for pump run, off-on selector switch and green pilot light for unit power, off-on selector switch and red pilot light for low water alarm, circuit breaker protection, motor rated starter relays, auxiliary contacts for alarm circuit and a 110v, 1ph, 9ft plug in power cord.

Suction and Discharge Piping

Suction piping shall be brass with drain connection and plug. Suction isolation valve shall be a brass body gate. Discharge piping shall be brass with a brass body check valve, field adjustable pressure switch, pressure gauge, pressure relief valve and 1/2" N.P.T. male discharge pipe connection. Interconnecting piping to and from pump will be high pressure poly reinforced braided hose.

Low Level Switch

Float switch shall be made of ABS plastic. The float will be tethered on the upper portion of the tank. Low tank level will deactivate all pumping operations and activate a low level visual and audible alarm on the control panel.

Standard System Settings

G.P.M. 2.0 SYSTEM PRESSURE: ON - 10 PSI / OFF - 40 PSI PRESSURE RELIEF VALVE: 100 PSI

Power Requirements

VOLTAGE: 110v / 1ph / 60Hz F.L.A. 15.0 AMPS

Options

- ON/OFF - PSI**
Special system pressure settings (ON-____ PSI / OFF-____ PSI)
- AMT**
Timed mixing loop keeps glycol mixed in tank and cycles pump
- ALT**
Pump alternator rotates lead pump in duplex single loop systems
- ET**
Expansion tank, 2-gallon steel
- ET-PRV**
Pressure reducing valve with 2-gallon expansion tank (8 - 50 psi pressure setting)
- SET**
Expansion tank, 2-gallon stainless steel
- HFP**
High flow pump (4.5 gpm @ 100 psi)
- HLA**
High water alarm

- 1 TANK POLYETHYLENE 55 GALLONS
- 2 COVER POLYETHYLENE HINGED
- 3 ELECTRICAL PANEL UL/CUL 508A
- 4 BASE ASSEMBLY
- 5 PUMP 1 ASSEMBLY
- 6 SUCTION ISOLATION VALVE - PUMP 1
- 7 CHECK VALVE - PUMP 1
- 8 PRESSURE GAUGE - PUMP 1
- 9 PRESSURE SWITCH - PUMP 1
- 10 PRESSURE RELIEF VALVE - PUMP 1
- 11 FLOAT SWITCH (LOW WATER)
- 12 PUMP 2 ASSEMBLY
- 13 SUCTION ISOLATION VALVE - PUMP 2
- 14 CHECK VALVE - PUMP 2
- 15 PRESSURE GAUGE - PUMP 2
- 16 PRESSURE SWITCH - PUMP 2
- 17 PRESSURE RELIEF VALVE - PUMP 2

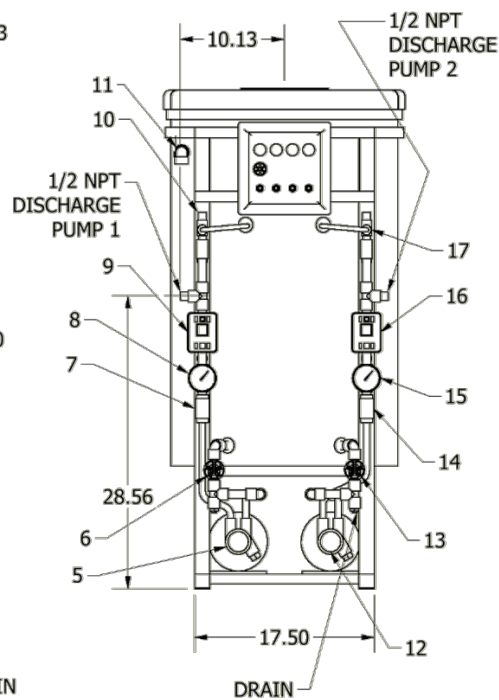
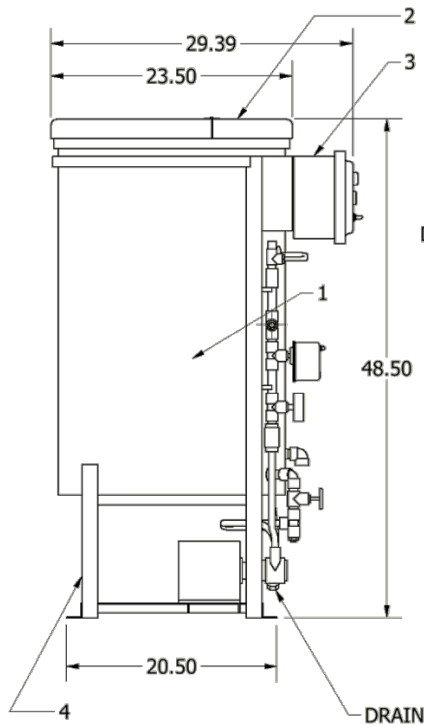
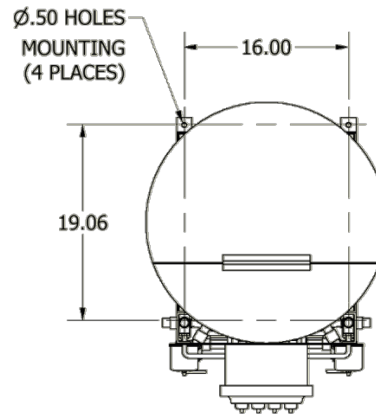

JOB NAME	<input type="text"/>	CONTRACTOR	<input type="text"/>
ORDER NO.	<input type="text"/>	SUBMITTED BY	<input type="text"/> DATE
SALES REP.	<input type="text"/>	APPROVED BY	<input type="text"/> DATE
ENGINEER	<input type="text"/>	NOTES	
LOCATION	<input type="text"/>	<input type="text"/>	