

VEXO X-POT HFHP 30 Bar Data Sheet

Code	VEXO® Ref	Description
V-XPOTHFHP30	X-POT HFHP® Unit	VEXO® X-POT HFHP® 10 Bar Side Stream Filtration & Dosing Unit

Feature	Description
Maximum System Working Pressure	30 Bar
Suitable For System Volumes Up to	2,592,000 Litres
Flow Rate Through the Vessel	Up to 30.0L/sec (1800L/min)
Temperature Range	0°C to 95°C
Filtration Rate	Down to 1 Micron
Weight	Dry: 143KG - Operational: 195KG
Isolation Valve Connections	6" PN40 Flanged
Dosing Capacity	143L
Filter Body Mounting	Floor Standing
Vessel Body	304 Stainless Steel – complies with PED 2014/68/EU SEP
Baffle Plate	316 Stainless Steel
Magnet Grate	316 Stainless Steel
Magnets x 52No	Neodymium Rare Earth
Bag Filter x 5No (1 Off each size)	Polypropylene Needlefelt Type 19-2G (100, 50, 25, 5 & 1 micron)
Isolation Valves, NRVs and Fittings	304 Stainless Steel
AAV	304 Stainless Steel

Crate Contents (Unit & Components)



Feature	Benefits
Compliance	Engineered for BSRIA BG29 and BG50 Guidance for Chemical Dosing, Magnetic Filtration, Fine Filtration, Passive De-aeration and Side Stream Filtration.
Magnetic filter	Removes magnetic system debris, increases the lifespan of the boiler, chiller and cooling system components, reduces carbon emissions, increases fuel efficiency & increases the lifespan of the Bag Filter.
Polypropylene Needlefelt Bag Filter	Removes non-magnetic system debris, available in 100, 50, 25, 5 & 1 micron filtration rates, ensures coalescence micro-bubble formation on the surface of the filter & surpasses BSRIA Guidance for filtration rates.
Automatic Air Separator	Ensures the system micro-bubbles and air are emitted from the system and helps to reduce corrosion rates and decreases stress on system components.
143L Dosing Pot Capacity	Enables installers and maintenance personnel to quickly dose the system with water treatment additives.
Connections 6" PN40 Flanged	Suitable for all types of closed loop LTHW Heating and Cooling Water Systems up to 2,592,000 litres in volume.
52No 8,000 Gauss Neodymium Magnets	Each magnet is fully encased in 304SS shell, easily removable from the 316SS Magnet Grate for cleaning & fully submerged in the system flow for increased filtration.
Installation Bracket & Rod	For simple installation use 4 off bolt holes in feet.
Servicing	The cleaning of the filters can simply be achieved without the need to shut the main system down and the dosing of water treatment chemicals is achieved simply and safely, again without the need to shut the system down.
Enhanced Performance	The ingenious design ensures that the filter will continue to perform should regular maintenance not be carried out.
Stainless Steel Components	All major components are manufactured from 304SS or 316SS for improved lifecycle and reliability.
Full Bore Ball Valve isolation Valves	The 304SS isolation valves do not restrict system flow & increases ease of installation.
Warranty	8 Year standard warranty.

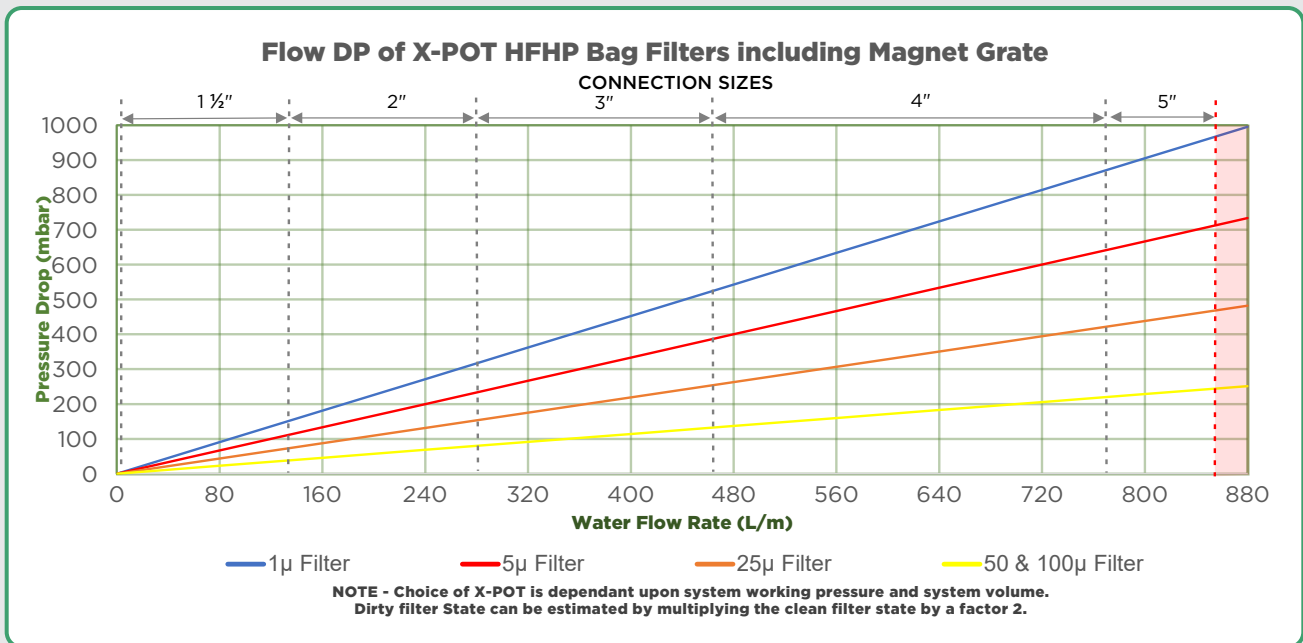

VE XO X-POT Simple Schematics

INSTALLATION EXAMPLE

24
Hours

System
Volume

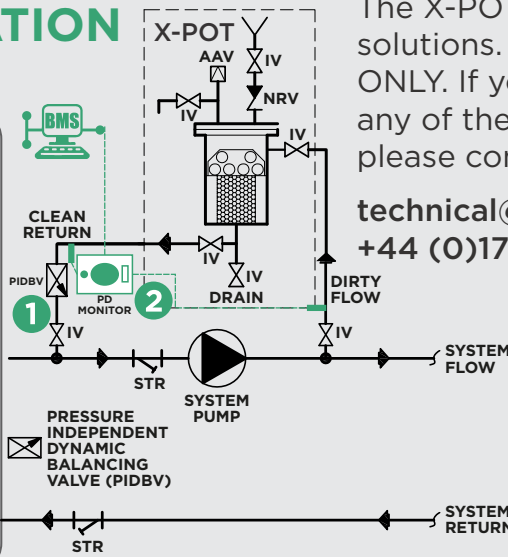

The X-POT provides a dumber of installation solutions. These examples are INDICATIVE ONLY. If your system cannot accommodate any of these scenarios due to complexity, please contact the VEXO Technical Team:

technical@VEXOint.com
+44 (0)1767 500 150

Which connections and X-POT?

The size of the connections to the X-POT is determined by the total system volume being circulated through the X-POT in a 24 Hour period.

SYSTEM VOLUME = $\frac{1}{\text{sec}}$
86,400sec

0.083 - 0.4 l/s = ½" Conn.
0.4 - 0.6 l/s = ¾" Conn.
0.6 - 1.0 l/s = 1" Conn.
1.0 - 1.2 l/s = 1 ¼" Conn.
1.2 - 2.1 l/s = 1 ½" Conn.
2.1 - 3.5 l/s = 2" Conn.

EXAMPLES

Working Pressure: 3 Bar
System Volume 22,500L = 0.26l/s
Chosen Vessel: X-POT Compact
Connection Size: ½"

Working Pressure: 10 Bar
System Volume 90,000L = 1.04l/s
Chosen Vessel: X-POT XP
Connection Size: 1 ¼"

- ISOLATION VALVE
- NON RETURN VALVE
- STRAINER
- AUTO AIR VENT
- PRESSURE GAUGE
- TEMPERATURE GAUGE
- PRESSURE RELEASE VALVE
- FLEX CONNECTION
- PUMP
- VEXO™ PD-MONITOR
- PRESSURE INDEPENDENT DYNAMIC BALANCING VALVE
- COMMISSIONING VALVE
- 3 PORT VALVE

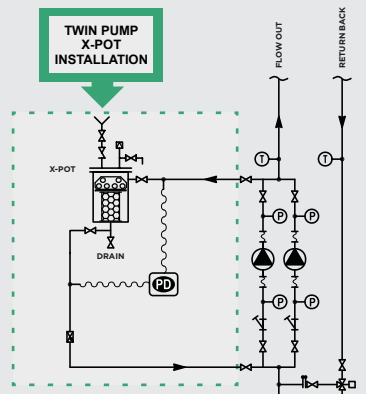

TWIN PUMP X-POT INSTALLATION

THE X-POT® SHOULD BE FIT ON THE SECONDARY HEATING CIRCUIT TO ENSURE BULK WATER SYSTEM PROTECTION

ZONE/MULTIPLE PUMP X-POT INSTALLATION

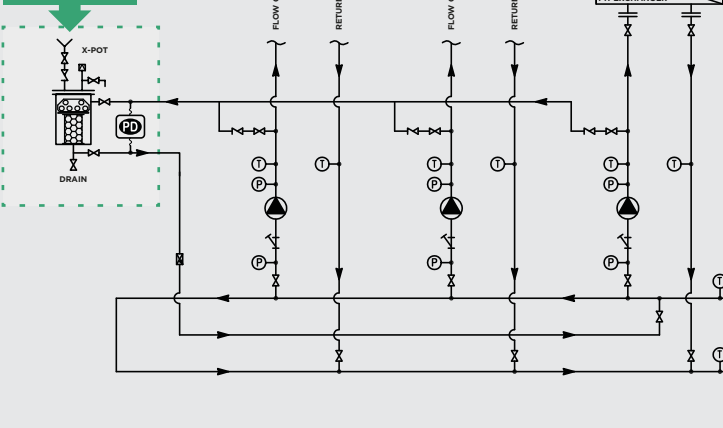

SINGLE PUMP X-POT INSTALLATION

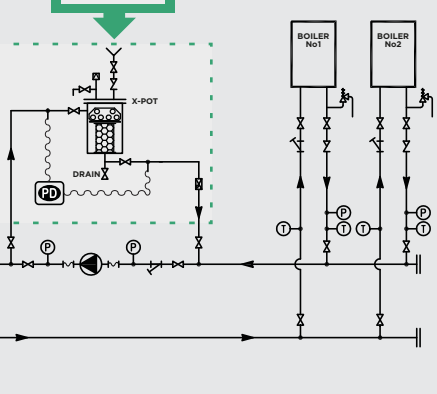

VEXO X-POT XP Dimensions

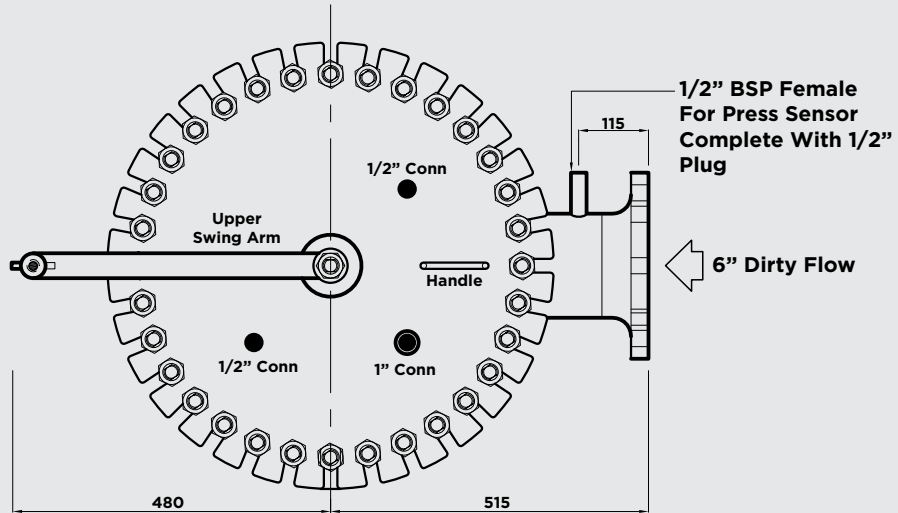

Plan View

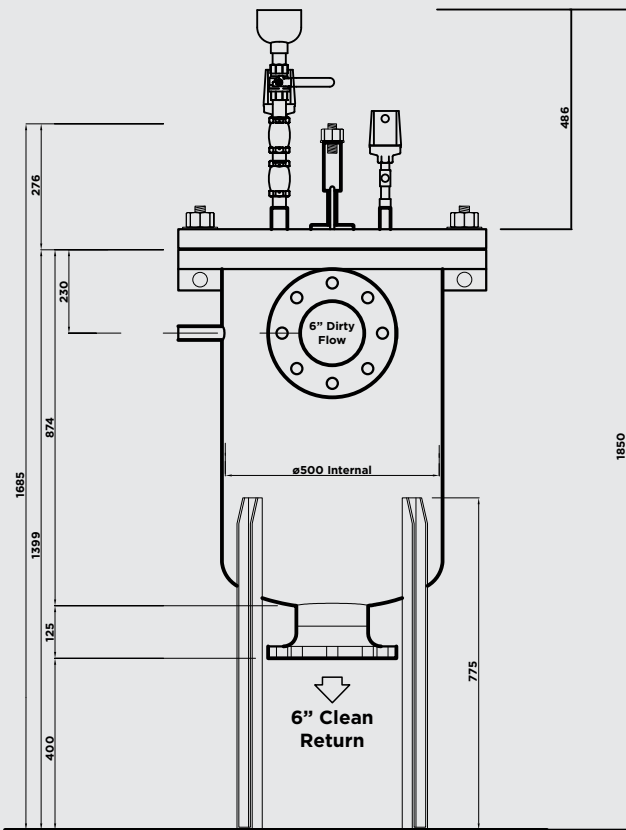

Side View

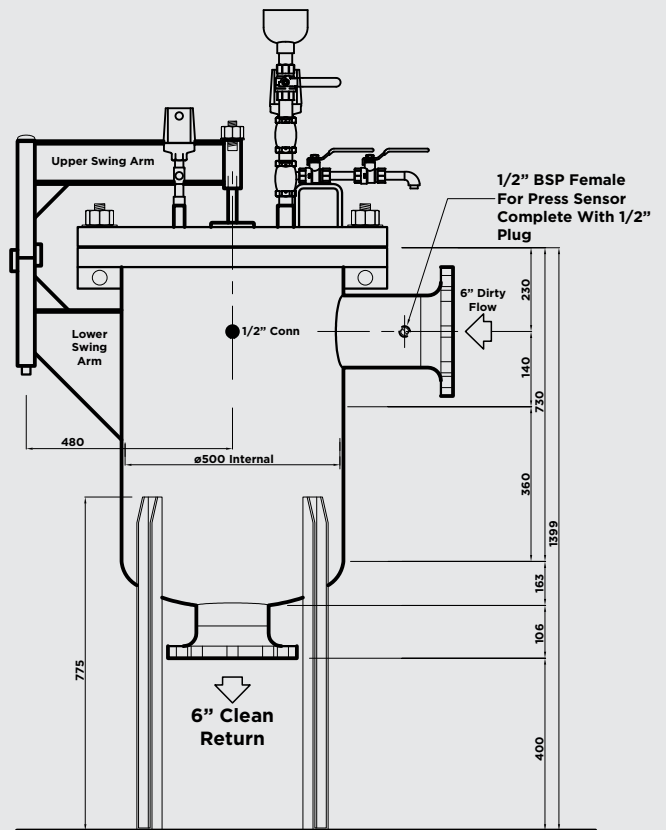

Front View

VEXO X-POT Disposal Methods

Feature	Description
Vessel & Fittings	Recycle - Scrap metal
Baffle Plate	Recycle - Scrap metal
Magnets	Remove from metal grate & recycle separately
Plastic Wrap	Remove from unit & place in plastic recycling waste stream
AAV	Recycle - Scrap metal
Bag Filter	<p>Spent Bag Disposal - The spent filter bags should be disposed of in a responsible manner. The filter itself can be disposed of by incineration or as landfill by an authorised contractor; however, it is important for the user to check how the contaminant contained in the filter should be disposed of in accordance with local Health and Safety regulations. For UK filter users Veolia offers a 'Waste to Energy' disposal service. More information can be obtained at:</p> <p>https://www.veolia.co.uk/about-us/veolia-uk/recycling-reuse-and-treatment-facilities/</p>