

VEXO X-POT XP Data Sheet

Code	VEXO® Ref	Description
V-XPOTXP	X-POT XP® Unit	VEXO® X-POT XP® Side Stream Filtration & Dosing Unit
V-XXP(CONT)PACK	X-POT XP® Contractor Pack	VEXO® X-POT XP® Contractor Pack

Feature	Description
Maximum System Working Pressure	16 Bar
Suitable For System Volumes Up to	302,400 Litres
Flow Rate Through the Vessel	0.083L/sec to 3.5L/sec (4.98L/min to 210L/min)
Temperature Range	0°C to 95°C
Filtration Rate	Down to 1 Micron
Weight	Dry: 45KG - Operational: 85KG
Isolation Valve Connections	2" BSP Female
Dosing Capacity	25L
Filter Body Mounting	Floor Standing
Vessel Body	304 Stainless Steel - complies with PED 2014/68/EU SEP
Baffle Plate	316 Stainless Steel
Magnet Grate	316 Stainless Steel
Magnets x 13No	Neodymium Rare Earth
Bag Filter x 5No (1 Off each size)	Polypropylene Needlefelt (100, 50, 25, 5 & 1 micron)
Isolation Valves, NRV and Fittings	304 Stainless Steel
AAV	Brass

Crate Contents (Unit & Components)

- 13 No. Neodymium Rare Earth Magnets & Stainless Steel Grate
- Stainless Steel Baffle Plate
- Bag Filter in Contractor Pack Only & Stainless Steel Filter Housing

Box Contents

Assembly & Operating Instructions are included

- Insulation Jacket (3 Parts)
- Auto Air Vent
- 1 Each of 100, 50, 25, 5 & 1 micron bag filters
- Pressure Assembly

Feature	Benefits
Compliance	Engineered for BSRIA BG29 and BG50 Guidance for Chemical Dosing, Magnetic Filtration, Fine Filtration, Passive De-aeration and Side Stream Filtration.
Magnetic filter	Removes magnetic system debris, increases the lifespan of the boiler, chiller and cooling system components, reduces carbon emissions, increases fuel efficiency & increases the lifespan of the Bag Filter.
Polypropylene Needlefelt Bag Filter	Removes non-magnetic system debris, available in 100, 50, 25, 5 & 1 micron filtration rates, ensures coalescence micro-bubble formation on the surface of the filter & surpasses BSRIA Guidance for filtration rates.
Automatic Air Separator	Ensures the system micro-bubbles and air are emitted from the system and helps to reduce corrosion rates and decreases stress on system components.
25L Dosing Pot Capacity	Enables installers and maintenance personnel to quickly dose the system with water treatment additives.
Connections 2" BSP	Suitable for all types of closed loop LTHW Heating and Cooling Water Systems up to 302,400 litres in volume.
13No 8,500 Gauss Neodymium Magnets	Each magnet is fully encased in 304SS shell, easily removable from the 316SS Magnet Grate for cleaning & fully submerged in the system flow for increased filtration.
Installation Bracket	For simple installation to wall + 4 off bolt holes in feet.
Servicing	The cleaning of the filters can simply be achieved without the need to shut the main system down and the dosing of water treatment chemicals is achieved simply and safely, again without the need to shut the system down.
Enhanced Performance	The ingenious design ensures that the filter will continue to perform should regular maintenance not be carried out.
Stainless Steel Components	All major components are manufactured from 304SS or 316SS for improved lifecycle and reliability.
Full Bore Ball Valve isolation Valves	The 304SS isolation valves do not restrict system flow & increases ease of installation.
Bespoke Insulation Jacket	Supplied as part of the Contractor Pack. The bespoke insulation jacket ensures heat losses are minimised.
Warranty	8 Year standard Warranty.

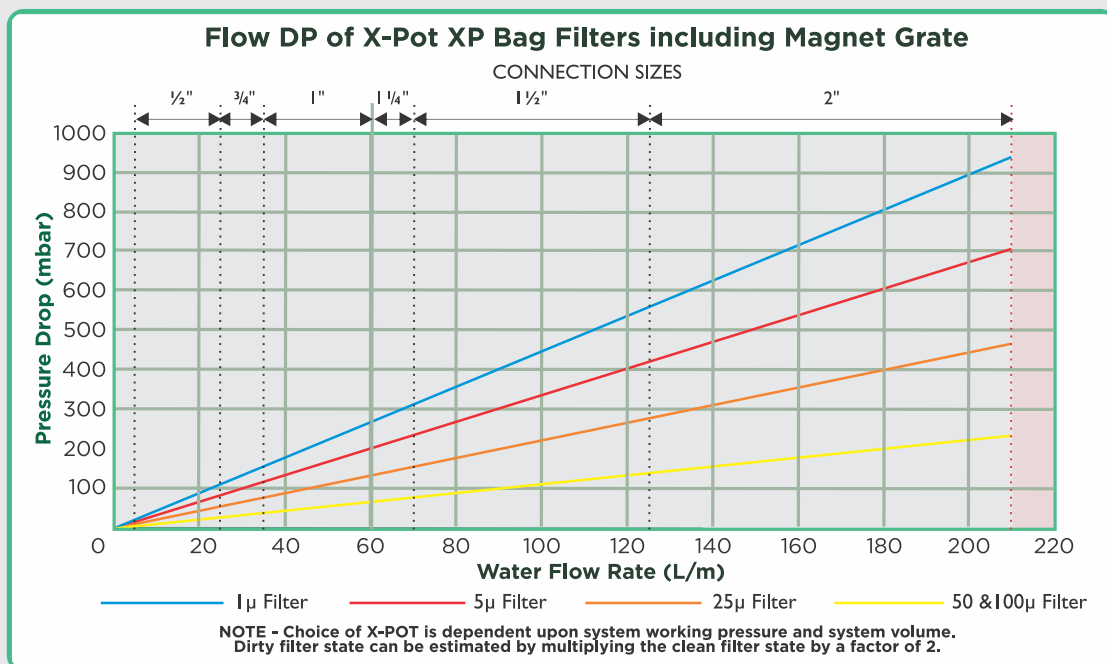

VEXO X-POT Simple Schematics

INSTALLATION EXAMPLE

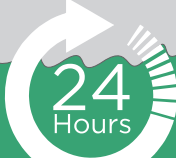

24 Hours
System Volume

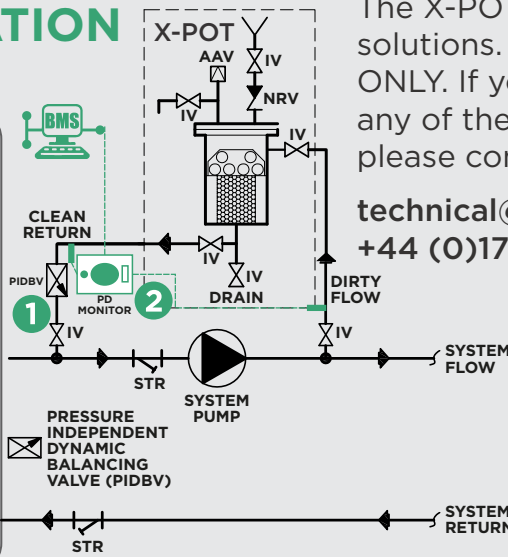

The X-POT provides a dumber of installation solutions. These examples are INDICATIVE ONLY. If your system cannot accommodate any of these scenarios due to complexity, please contact the **VEXO Technical Team:**

technical@VEXOint.com
+44 (0)1767 500 150



Which connections and X-POT?

The size of the connections to the X-POT is determined by the total system volume being circulated through the X-POT in a 24 Hour period.













SYSTEM VOLUME = 1/sec
86,400sec

0.083 - 0.4 l/s = ½" Conn.
0.4 - 0.6 l/s = ¾" Conn.
0.6 - 1.0 l/s = 1" Conn.
1.0 - 1.2 l/s = 1 ¼" Conn.
1.2 - 2.1 l/s = 1 ½" Conn.
2.1 - 3.5 l/s = 2" Conn.

EXAMPLES

Working Pressure: 3 Bar
System Volume 22,500L = 0.26l/s
Chosen Vessel: X-POT Compact
Connection Size: ½"

Working Pressure: 10 Bar
System Volume 90,000L = 1.04l/s
Chosen Vessel: X-POT XP
Connection Size: 1 ¼"

-  ISOLATION VALVE
-  NON RETURN VALVE
-  STRAINER
-  AUTO AIR VENT
-  PRESSURE GAUGE
-  TEMPERATURE GAUGE
-  PRESSURE RELEASE VALVE
-  FLEX CONNECTION
-  PUMP
-  VEXO™ PD-MONITOR
-  PRESSURE INDEPENDENT DYNAMIC BALANCING VALVE
-  COMMISSIONING VALVE
-  3 PORT VALVE

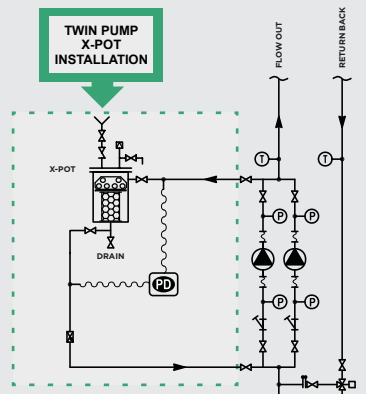

THE X-POT® SHOULD BE FIT ON THE SECONDARY HEATING CIRCUIT TO ENSURE BULK WATER SYSTEM PROTECTION

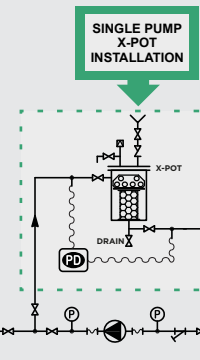
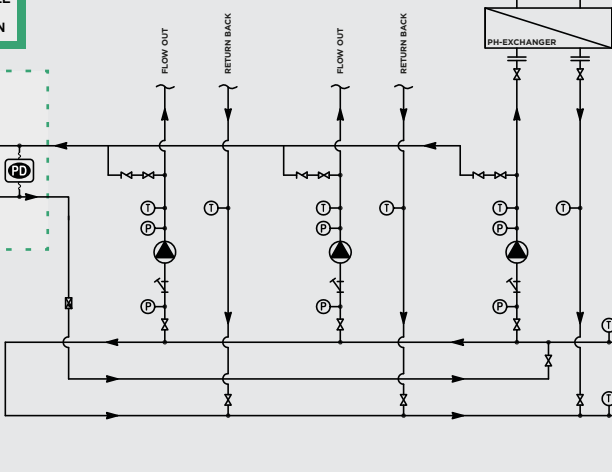
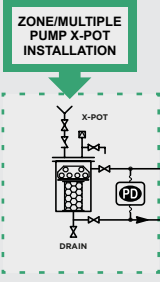

VEXO X-POT XP Dimensions

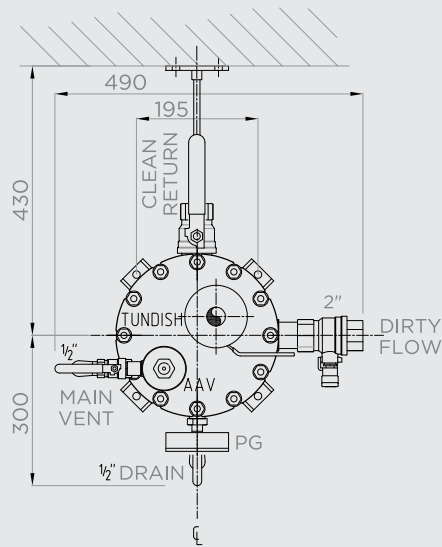

Plan View

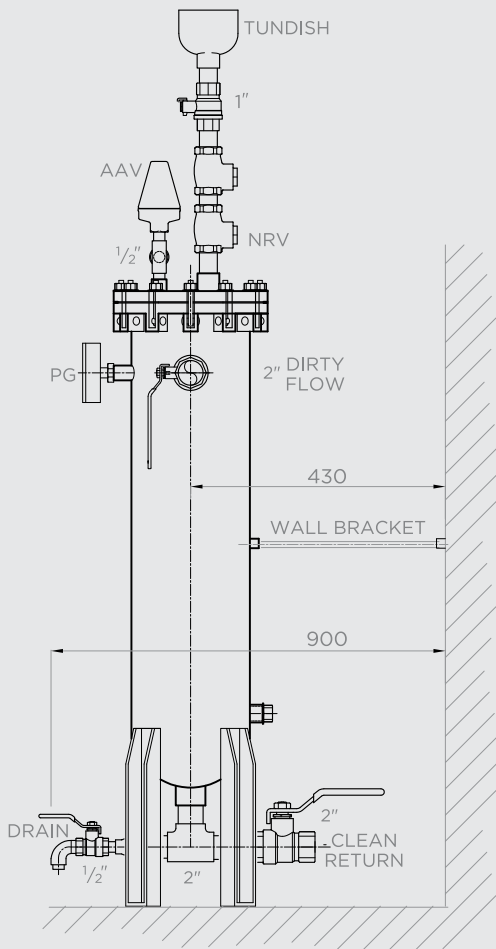

Side View

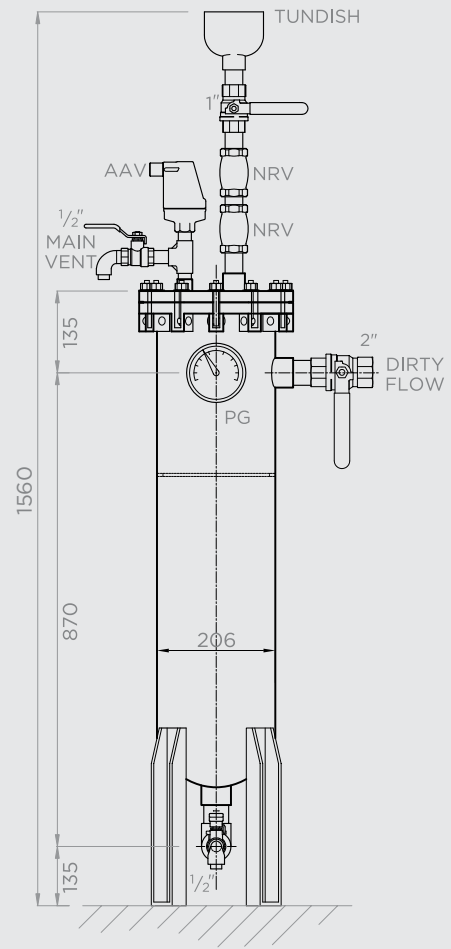

Front View

VEXO X-POT Disposal Methods

Feature	Description
Vessel & Fittings	Recycle - Scrap metal
Baffle Plate	Recycle - Scrap metal
Magnets	Remove from metal grate & recycle separately
Plastic Wrap	Remove from unit & place in plastic recycling waste stream
AAV	Recycle - Scrap metal
Insulation Jacket	Place in general waste
Bag Filter	<p>Spent Bag Disposal - The spent filter bags should be disposed of in a responsible manner. The filter itself can be disposed of by incineration or as landfill by an authorised contractor; however, it is important for the user to check how the contaminant contained in the filter should be disposed of in accordance with local Health and Safety regulations. For UK filter users Veolia offers a 'Waste to Energy' disposal service. More information can be obtained at:</p> <p>https://www.veolia.co.uk/about-us/veolia-uk/recycling-reuse-and-treatment-facilities/</p>